

Fiber - Optic Systems

Overview

Trunk Lines at the Moment

■ Migrating to Fiber Optics

Trunk lines carry many different kinds of signals—video, synchronization, audio, control, power supply—and consequently they're usually comprised of numerous different types of cables. As a result, conduits, electrical pits, and ladders tend to overflow with cabling, leaving hardly any room when lines must be added to upgrade or expand the system.

But, converting these disparate signals into optical signals and transmitting them using fiber optic cables greatly reduces the need for so many specialized cables. Converting trunk lines to fiber optics makes it much easier to design and upgrade equipment and systems, because once laid these lines can be used with considerable flexibility. Fiber optic cables also have smaller diameters, meaning they take up less space, a clear advantage in alleviating some of the problems of today's cable-stuffed broadcasting facilities.

■ Sending HD Signals Everywhere

HD-SDI signals can be transmitted only about 100 meters over standard coaxial cables (5C-FB). This means that when wiring rooms and buildings with coaxial cables, it's sometimes difficult to achieve an optimal layout or position equipment where it will be most convenient and useful.

Further, signal transmissions often need to cover unexpectedly long distances, and fiber optic cables, with their transmission distance measured in tens of kilometers, win hands-down over coaxial cables. This flexibility alleviates much of the conventional worry about cable routing and allows the equipment itself to take center stage.

The cost of optical signal converters has dropped radically, too—most can be had for a few hundred dollars—making it difficult these days to find reasons not to introduce fiber optic systems!

Diversified Needs for Optical Conversion

■ It is not just the HD-SDI signal

It is not just the HD-SDI signal that is converted into optical signals. For example, there is a case in which the HD-SDI signal is converted into optical signals along with the control signal to transmit video images during recording in a studio. Converting various signals into optical signals allows them to be transmitted through fiber-optic cables, eliminating the necessity of separately preparing metal cables.

■ Advantages of Fiber Optic Transmission in the Field

With it now so easy to convert transmissions into optical signals, fiber optic systems are better suited than ever to field recording applications. Newly developed extra-strong, extra-bendable optical fibers have finally reduced past concerns about cable durability, meaning that in applications like remote broadcasting, video, audio and other signals can all be transmitted on a single cable, one of the inherent merits of fiber optic systems.

Cable Diameters

Even with 100 cores (lines), a fiber optic cable has an external diameter of just 11.5 mm. Compare that to a typical coaxial cable and the difference is clear.

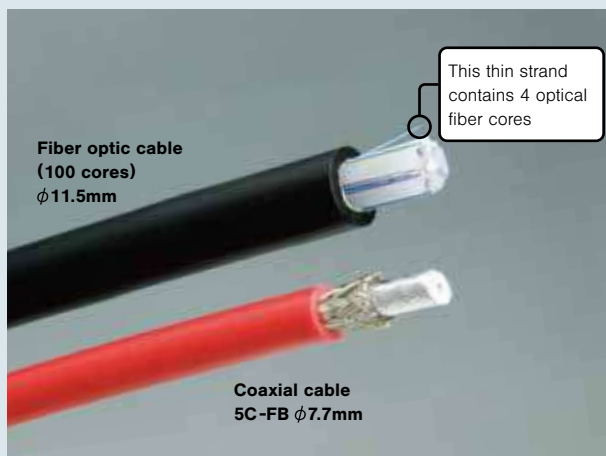

Example of an Optical Fiber Trunk Line

Fiber optic systems are used in signal transmissions within a single broadcast station, or between a main building and an annex building.

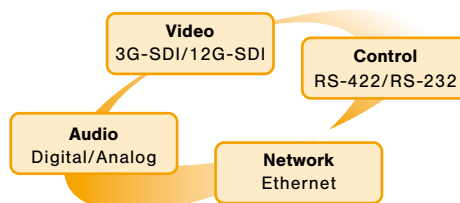
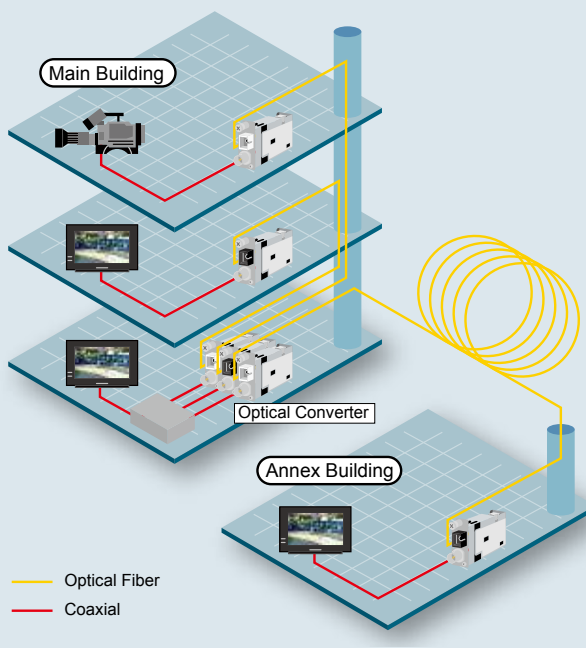

Tough & Flexible HFO Camera Cable



(See page 19)

Important Fiber Optic Line Considerations

Light Receiving Power

In optical transmission, transmission quality is evaluated by the relationship between "light receiving power" and "error rate." Error rate is dependent upon the signal to noise ratio (S/N), but since the noise level is thought of as being at a set level independent of the signal strength, the strength of the signal (light receiving power) at the receiver influences S/N considerably, in turn affecting the error rate. Therefore, to maintain a specified transmission quality, it is necessary to design light receiving power to be above the minimum light receiving power of the receiver. The graph at right is an example showing the light receiving power and error rate within the combination of a TX and a RX. From this graph, we can estimate that to get an error rate of 2×10^{-18} (to ensure a probability of 1 for transmission errors during 10 years of continuous operation), the light receiving power of the RX must be set greater than -24.3 dBm assuming the signal source and the TX are connected with a coaxial cable 1 meter in length (SMPTE connection standard).

If the signal source and the TX are connected by a coaxial cable 190 meters in length, then the light receiving power of the RX must be more than -23.6 dBm , from which we can see that the light receiving power deteriorates by about 1 dB as compared with the connection standard.

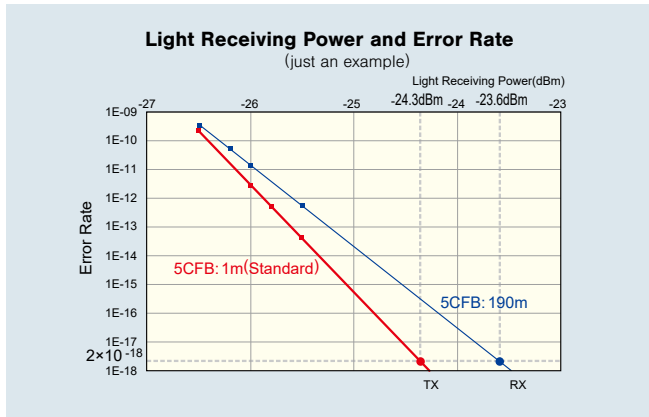

Loss Budget (LB)

Loss budget is the difference between the optical power output (P1) from the EO converter and the light reception sensitivity (P2) of the OE converter.

$$LB = P1 - P2$$

Example) If the optical power output P1 = -2.5 dBm and the reception sensitivity P2 = -22 dBm :

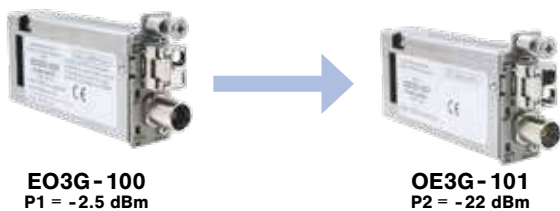

$$LB = -2.5 \text{ dBm} - (-22 \text{ dBm}) = 19.5 \text{ dB}$$

In EO/OE system design, 1) cable attenuation loss, 2) connector insertion loss, 3) fusion splice connection loss, and 4) Mux/Demux insertion loss must be calculated so that they are less than the loss budget (LB) of the optic link.

For SDI system, since the loss of Mux/Demux is greater than that of the fiber attenuation loss, it would be essential you to consider such loss factors when you configure the system.

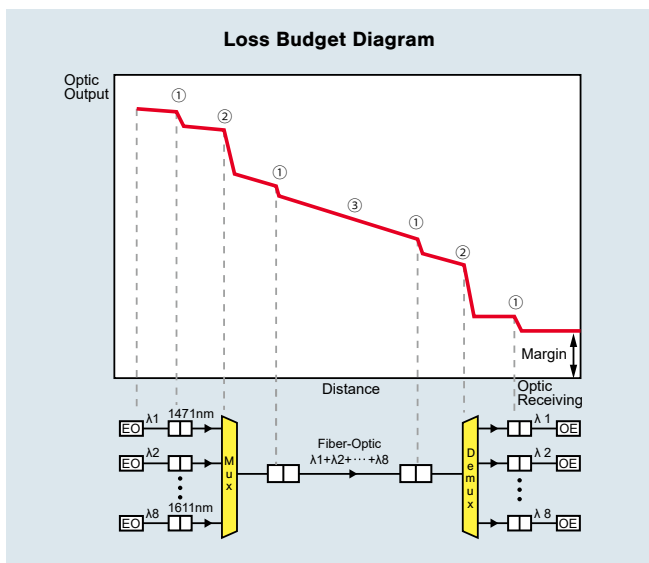

Loss Attenuation

Loss Factor	Value
① Connector Insertion Loss	0.5 dB/Point
② Mux/Demux	2~3 dB/Point
③ Fiber Cable	0.3 dB/km(*)
Splitter	0.5 dB/Main 10 dB/Branch
Divider	3 dB/Point
Fusion Splice Loss	0.2 dB/Point
System Margin	2~6 dB

* 0.5~1.0 dB/km for Dark fiber

Fiber - Optic Systems

Overview

Wavelength Multiplexing Systems

Multiplexing

"Multiplexing" is a technology that allows multiple signals with different wavelengths to be transmitted together over a single optical fiber. Three general types of multiplexing – WDM, CWDM and DWDM – offer increasing signal-carrying capacities, as described below.

Wavelength Division Multiplexing (WDM)

WDM is the simplest form of multiplexing and uses two wavelengths of 1310nm and 1551nm. Unlike when using an optical divider, insertion loss can be kept below 0.5dB.

Coarse Wavelength Division Multiplexing (CWDM)

CWDM systems use 8 wavelengths (20nm grid) primarily between 1471nm and 1611nm. To these it is also possible to add 8 more between 1271nm and 1451nm to allow a maximum of 16 wavelengths to be carried as a single multiplexed transmission. An ultra-thin membrane filter on the optical multiplexer/demultiplexer (mux/demux) keeps insertion loss at just 2-3dB.

*CWDM standardized through ITU G695.

Optical Converter (TX for CWDM)

Canare's CWDM optical converter uses a DFB laser, which offers a much tighter spectrum than FP lasers. Up to 16 different wavelengths fall within 1271nm and 1611 nm in 20nm intervals.

The wavelengths in the 20nm grid between 1391nm and 1411nm are not used because their proximity to the water peak results in too much attenuation.

Optical Fiber Transmission Loss Characteristics

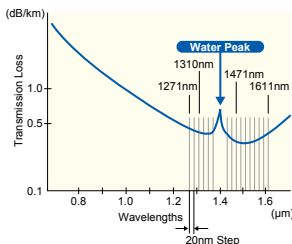

Optical Multiplexer/Demultiplexers

The optical signals output from the optical converter (TX) are combined into a single signal by the multiplexer (mux) and transmitted along a single optical fiber. At the receiving end, these combined optical signals are demultiplexed (demux) to split them back into their original component 8 signals.

Optical mux/demuxers are bi-directional, so the same model can be used for transmitting and receiving on each end. It's also possible to use 4 wavelengths out of the 8 for transmitting and the remaining four for receiving. Both 8-wavelength and 16-wavelength models are available, and combining these with an optical converter allows a variety of system constructions with many uses.

Optical Converter (RX)

Canare's optical converter (RX) converts an optical signal comprised of 8 different wavelengths into electrical signals. This converter is common to all wavelengths and one converter is required for each wavelength.

Once optical fiber cables have been laid, multiplexing the transmissions carried on them eliminates the need to purchase and install new cables when more transmission lines are needed.

Eight Canare optical converters and an FCWDM-8B mux/demuxer can be installed compactly on a single 161UPSC 1RU-size platform, effectively allowing an 8-wavelength transmission system to be achieved in just 1RU of space.

Multiplexing (CWDM)

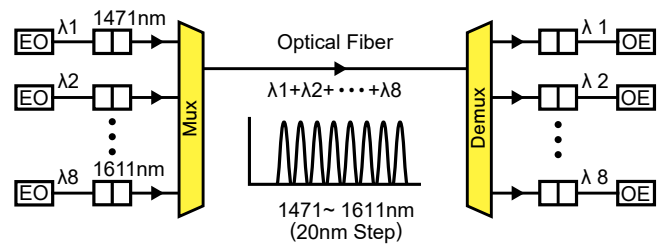

8-wavelength CWDM system example

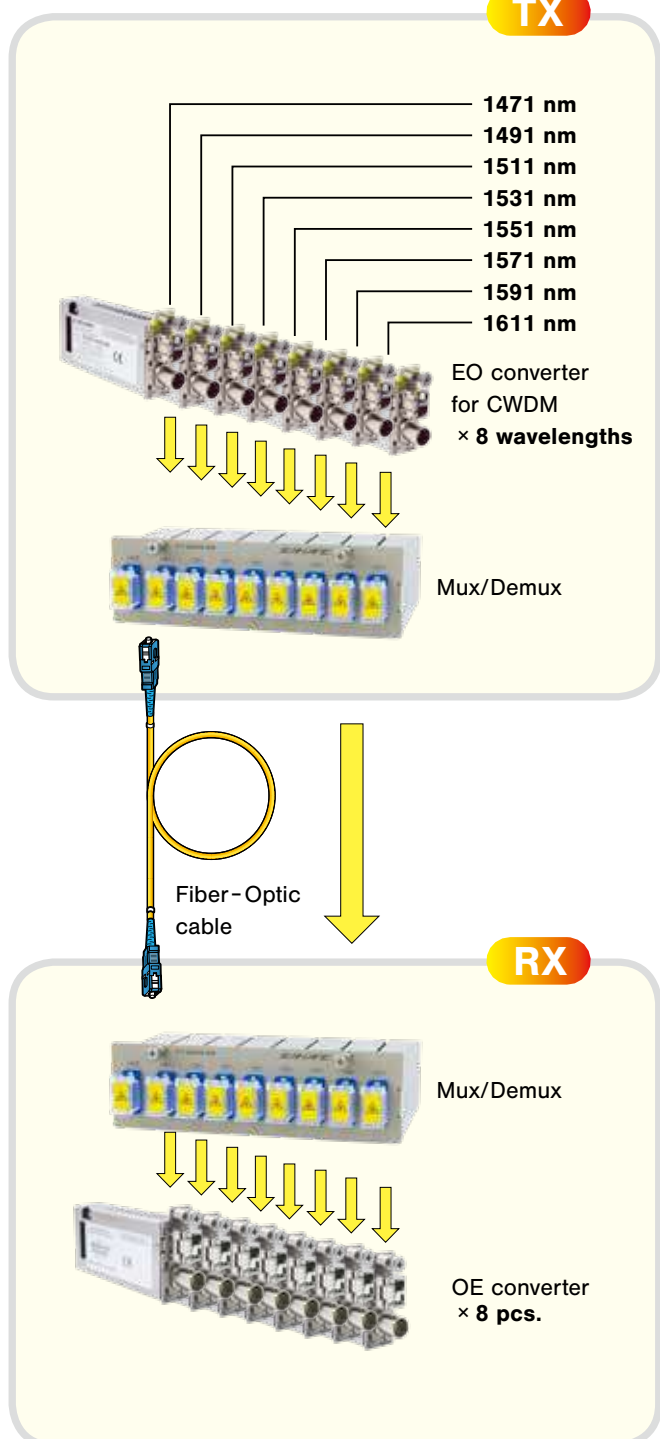

Note: Please use with Canare platform.

12G-SDI EO/OE Converters

Electric to Optic Converter (TX)

Model	Wavelength	Emission	Occupancy
EO12G-100B	1310 nm	-2 dBm	1 slot
New EO12G-100A-**	1271-1451nm for CWDM*	-1 dBm	1 slot

*Refer to the following information to specify the wavelength and the model number.

Optic to Electric Converter (RX)

Model	Wavelength	Sensitivity	Occupancy
OE12G-101B	1260-1650 nm	-13 dBm	1 slot

Key Features and Benefits

- Supports 12G/6G/3G/HD/SD-SDI and DVB-ASI
- Capable of Pathological Test Pattern transmission (SMPTE RP-178, 198 Check Field Test Pattern)
- Super low latency
- Compact size
- No complicated settings
- 3-color LED signal indication

Specifications

Model	EO12G-100B	EO12G-100A-**	OE12G-101B
Convertibility	Electric to Optic		Optic to Electric
Fiber Type	Single Mode		
Optical Input	N/A		1 × LC
Optical Output	1 × LC		N/A
SDI Input	1 × 75Ω BNC		N/A
SDI Output	N/A		1 × 75Ω BNC
Dimensions	17 × 43.4 × 78.4 mm		
Weight	Approx. 95 g		
Standards	SMPTE ST 2082-1, 2081-1, 424, 297-1, 292-1, 259, EN50083-9		



EO12G-100B

12G-SDI



OE12G-101B

12G-SDI



EO12G-100A-**

12G-SDI

Ordering Information for EO12G-100A-**

Wavelength	27	29	31	33	35	37	43	45	47	49	51	53	55	57	59	61
1271nm	Coming Soon															
1291nm		Coming Soon														
1311nm			Coming Soon													
1331nm				Coming Soon												
1351nm					Coming Soon											
1371nm						Coming Soon										
1431nm							Coming Soon									
1451nm								Coming Soon								

Note: Platform is required for power supply (page 14).

12G-SDI Repeater

Equalizes and reclocks SDI signals to extend the transmission distance over a coaxial cable.

Model	Supporting Signals	Occupancy
EE12G-100	12G/6G/3G/HD/SD-SDI, DVB-ASI	1 slot

Key Features and Benefits

- Supports 12G/6G/3G/HD/SD-SDI and DVB-ASI
- 12G-SDI cable equalization: 100 m over L-5.5CUHD (Typ.)
- 3-color LED signal indication
- Allows for efficient use of existing cable infrastructure.

Specifications

I/O Connectors	2 × 75Ω BNC
Standards	SMPTE ST 2082-1, 2081-1, 424, 292-1, 259, EN50083-9



EE12G-100

12G-SDI

Dimensions: 17 × 43.4 × 78.4 mm
Weight: 85g

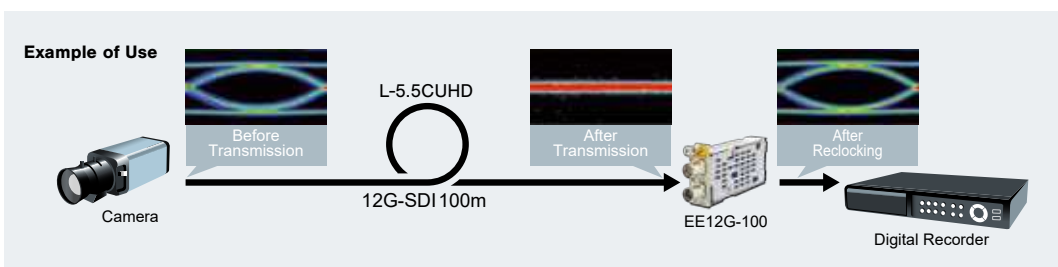

Note: Platform is required for power supply (page 14).

Technical Trend

Fiber-Optic Systems

Connectors

Cables

Panels & Patchbays

Multichannel Systems

Cable Assemblies

Fiber - Optic Systems

EO/OE Converters

3G-SDI EO/OE Converters

■ Electric to Optic Converter (TX)

Model	Wavelength	Emission	Monitor Out	Occupancy
EO3G-100	1310 nm	-2.5 dBm	No	1 slot
EO3G-200	1310 nm	-2.5 dBm	Yes	2 slots
EO3G-100A-**	1271 - 1611 nm for CWDM*	+2.5 dBm	No	1 slot

*Refer to the following information to specify the wavelength and the model number.

■ Optic to Electric Converter (RX)

Model	Wavelength	Sensitivity	Dual Out	Occupancy
OE3G-101	1200 - 1620 nm	-22 dBm	No	1 slot
OE3G-201	1200 - 1620 nm	-22 dBm	Yes	2 slots

Key Features and Benefits

- Supports 3G/HD/SD-SDI and DVB-ASI
- Capable of Pathological Test Pattern transmission (SMPTE RP-178, 198 Check Field Test Pattern)
- Super low latency
- Compact size
- No complicated settings
- Cost effective

■ Specifications

Model	EO3G-100	EO3G-200	EO3G-100A	OE3G-101	OE3G-201
Convertibility	Electric to Optic			Optic to Electric	
Optical Connector	1 × LC (output)			1 × LC (input)	
Fiber Type	Single Mode				
SDI Input	1 × 75Ω BNC	1 × 75Ω BNC	1 × 75Ω BNC	N/A	N/A
SDI Output	N/A	1 × 75Ω BNC (no-reclocked)	N/A	1 × 75Ω BNC	2 × 75Ω BNC
Dimensions (mm)	17 × 43.4 × 78.4	35.5 × 43.4 × 78	17 × 43.4 × 78.4	17 × 43.4 × 78.4	35.5 × 43.4 × 78
Weight (approx.)	100 g	150 g	95 g	100 g	150 g
Standards	SMPTE ST 259, 292-1, 297-1, 424, EN50083-9				



EO3G-100



EO3G-200
(with Monitor Output)



OE3G-101



OE3G-201
(with Dual Output)

Ordering Information for EO3G-100A-**

EO3G-100A-**27** - Wavelength



EO3G-100A-**

27	1271nm	47	1471nm
29	1291nm	49	1491nm
31	1311nm	51	1511nm
33	1331nm	53	1531nm
35	1351nm	55	1551nm
37	1371nm	57	1571nm
43	1431nm	59	1591nm
45	1451nm	61	1611nm

Note: Platform is required for power supply (page 14).

Technical Note

Jitter

The timing deviation of the periodic signal waveform is called jitter. For serial data signals such as SDI signals, jitter occurs due to the deviation of reference clock signal, reflection caused by connection through coaxial cables or between devices, loss of DC and high frequency components, the influence of noise from the equipment itself or from the outside. In the worst case, an error occurs in clock data recovery due to this jitter and that with SDI signals, noise may appear on the screen or signal transmission may come to be fail.

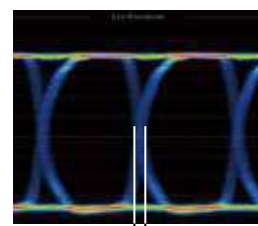

Jitter: 93 ps

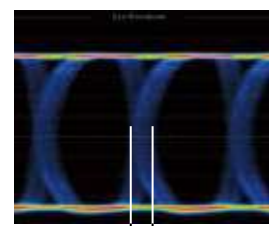

Jitter: 210 ps

AES 3id Optical Converters

Model	Wavelength	Emission	Sensitivity	Occupancy
EO-500-**	1471-1611 nm for CWDM*	-3 dBm	N/A	5 slots
OE-501	1200-1620 nm	N/A	-26 dBm	

* Refer to the following information to specify the wavelength.

Key Features and Benefits

- Multiplex and optically convert AES signals from up to 8 ports (16 audio channels) to allow them to be transmitted over long distance.
- Supports 8 wavelengths CWDM; enables max. 64 ports (128 audio channels) signals to transmit over a single optical fiber.
- AES-3id-1995 and SMPTE 276M
- Fully asynchronous multiplex transmission.
- Word clock can be transmitted (30kHz to 50kHz).
- Dolby-E compatible

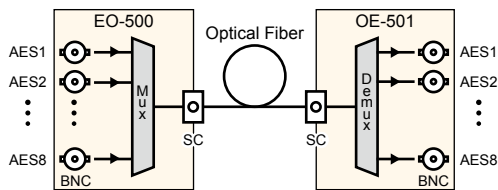

Specifications

Model	EO-500-**	OE-501
Convertibility	Electric to Optic	Optic to Electric
Fiber Type	Single Mode	
Optic Connector	1 × SC (output)	1 × SC (input)
AES I/O Connector	8 × 75Ω BNC (input)	8 × 75Ω BNC (output)
Dimensions	91 × 43.4 × 76.2 mm	
Weight	174 g	
Standards	AES-3id-1995, SMPTE ST 276	



EO-500-55



OE-501

Ordering Information for EO-500-**

EO-500- [47]	Wavelength
47	1471nm
49	1491nm
51	1511nm
53	1531nm
55	1551nm
57	1571nm
59	1591nm
61	1611nm

Technical Trend

Fiber-Optic Systems

Connectors

Cables

Panels & Patchbays

Multichannel Systems

Cable Assemblies

Note: Platform is required for power supply (page 14).

Analog Audio Optical Converters

Model	Wavelength	Occupancy	Remark
TRM-540	1310 nm	5 slots	Work with TRM-541.
TRM-541	1550 nm		Work with TRM-540.
TRM-540A-**	1471-1611 nm for CWDM (*1)		Work with TRM-540A-** of a different wavelength (*2).

*1) Refer to the following information to specify the wavelength and the model number.
*2) TRM-540A-** does not work with TRM-540 or TRM-541.

Key Features and Benefits

- Enables line level audio signals to transmit long distance over a fiber-optic cable.
- 8 channel transmission (4-channel inputs/4-channel outputs)
- Maximum input/output voltage: +24 dBu (balanced)
- Supports 600Ω input by each channel with selector switches.

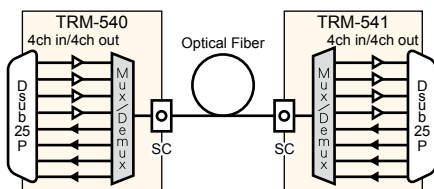

Block Diagram of TRM-540 and TRM-541

Specifications

Model	TRM-540, TRM-541	TRM-540A-**
Fiber Type	Single Mode	
Optic I/O Connector	1 × SC	2 × LC
Audio I/O Connector	1 × D sub 25 pin (F)	
Frequency Response	20 Hz - 40 kHz (-3 dB, +0.1 dB)	
Dimensions	91 × 43.4 × 78.4 mm	
Weight	265 g	



TRM-540



TRM-540A-**

Ordering Information for TRM-540A-**

TRM-540A- [47]	Wavelength
47	1471nm
49	1491nm
51	1511nm
53	1531nm
55	1551nm
57	1571nm
59	1591nm
61	1611nm

Note: Platform or Stand Alone Kit required for power supply (page 14).

Fiber - Optic Systems

EO/OE Converters

1000BASE-T Optical Converters

Model	Wavelength	Occupancy	Remark
TRM-300-G31	1310 nm	2 slots	Work with TRM-300-G55.
TRM-300-G55	1550 nm		Work with TRM-300-G31.
TRM-300A-G**	1471-1611 nm for CWDM (*1)		Work with TRM-300A-G** of a different wavelength (*2).

*1) Refer to the following information to specify the wavelength and the model number.
*2) TRM-300A-G** does not work with TRM-300-G31 or TRM-300-G55.

Key Features and Benefits

- Media converters for Gigabit Ethernet 1000BASE-T*
*No backwards compatibility with other Ethernet standards such as 100BASE-TX.
- Super-low latency: less than 1 micro-second.
- Extends communications up to 20 km (condition: line loss 0.5 dB/km)
- Bi-directional optical communication

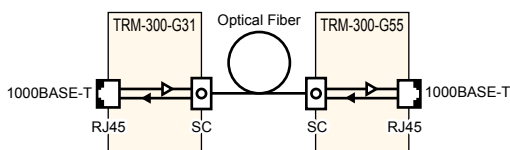

Block Diagram of TRM-300-G31 and TRM-300-G55

Specifications

Model	TRM-300-G31, TRM-300-G55	TRM-300A-G**
Fiber Type	Single Mode	
Optic I/O Connector	1 × SC	2 × LC
Ethernet I/O Connector	1 × RJ45	
Dimensions	35.5 × 43.4 × 76 mm	
Weight (approx.)	155 g	
Standards	IEEE 802.3ab (1000BASE-T)	



TRM-300-G31

TRM-300A-G**

Ordering Information for TRM-300A-G**

TRM-300A-G	Wavelength
47	1471nm
49	1491nm
51	1511nm
53	1531nm
55	1551nm
57	1571nm
59	1591nm
61	1611nm

Note: Platform is required for power supply (page 14).

100BASE-TX Optical Converters

Model	Wavelength	Occupancy	Remark
TRM-210	1310 nm	2 slots	Work with TRM-211.
TRM-211	1550 nm		Work with TRM-210.
TRM-210A-**	1471-1611 nm for CWDM (*1)		Work with TRM-210A-** of a different wavelength (*2).

*1) Refer to the following information to specify the wavelength and the model number.
*2) TRM-210A-** does not work with TRM-210 or TRM-211.

Key Features and Benefits

- Media converters for Fast Ethernet 100BASE-TX*
*No backwards compatibility with other Ethernet standards such as 10BASE-T.
- Auto MDI/MDX
- Extends communications up to 30 km (condition: line loss 0.5 dB/km)
- Bi-directional optical communication

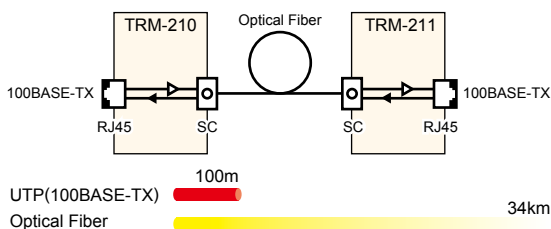

Block Diagram of TRM-210 and TRM-211

Specifications

Model	TRM-210, TRM-211	TRM-210A-**
Fiber Type	Single Mode	
Optic I/O Connector	1 × SC	2 × LC
Ethernet I/O Connector	1 × RJ45	
Dimensions	35.5 × 43.4 × 76.2 mm	
Weight (approx.)	103 g	110 g
Standards	IEEE 802.3u (100BASE-TX)	



TRM-210

TRM-210A-**

Ordering Information for TRM-210A-**

TRM-210A-	Wavelength
47	1471nm
49	1491nm
51	1511nm
53	1531nm
55	1551nm
57	1571nm
59	1591nm
61	1611nm

Note: Platform is required for power supply (page 14).

RS-422/RS-232 Optical Converters

Model	Wavelength	Occupancy	Remark
TRM-220	1310 nm	3 slots	Work with TRM-221.
TRM-221	1550 nm		Work with TRM-220.
TRM-220A-**	1471-1611 nm for CWDM (*1)		Work with TRM-220A-** of a different wavelength (*2).

*1) Refer to the following information to specify the wavelength and the model number.
 *2) TRM-220A-** does not work with TRM-220 or TRM-221.

Key Features and Benefits

- TIA-422, SMPTE ST 207, RS-232
- Usable in a case of RS-422 <=> RS-232
- Extends communications up to 30 km (condition: line loss 0.5 dB/km)
- Bi-directional optical communication

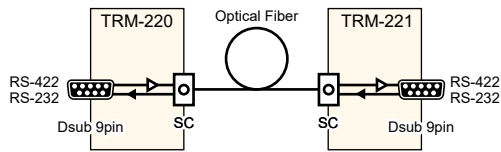

Block Diagram of TRM-220 and TRM-221

Specifications

Model	TRM-220, TRM-221	TRM-220A-**
Fiber Type	Single Mode	
Optic I/O Connector	1 x SC	2 x LC
Serial I/O Port	1 x Dsub 9 pin (F)	
Max. Data Rate	RS-422: 10 Mbps, RS-232: 1 Mbps	
Dimensions	54 x 43.4 x 76.2 mm	
Weight (approx.)	110 g	120 g
Standards	TIA-422, SMPTE ST 207, RS-232C	



TRM-220



TRM-220A-**

Ordering Information for TRM-220A-**

TRM-220A- [47]	Wavelength
47	1471nm
49	1491nm
51	1511nm
53	1531nm
55	1551nm
57	1571nm
59	1591nm
61	1611nm

Note: Platform is required for power supply (page 14).

More Converters

Model	Occupancy
TRM-100	3 slots
TRM-101	

Multiplex and optically convert HD-SDI and RS-485 signal to transmit long distance over a fiber-optic cable. Suited for HD surveillance camera system.

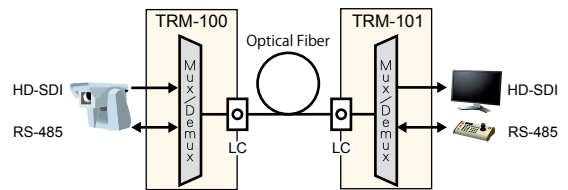

Model	Occupancy
TRM-400	3 slots
TRM-401	

Multiplex and optically convert analog video, stereo audio, RS-422, and relay signals to transmit long distance over a fiber-optic cable.

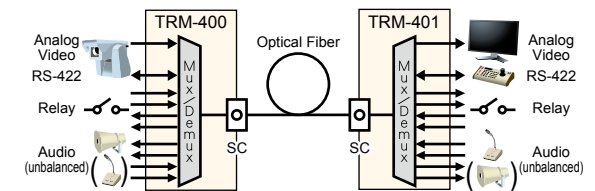

Model	Occupancy
TRM-230	3 slots
TRM-231	

Multiplex and optically convert 7 of each input/output relay signal and RS-422/232 signals to transmit long distance over a fiber-optic cable.

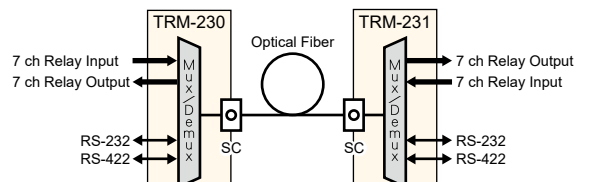

Note: Platform or Stand Alone Kit required for power supply (page 14).

Technical Trend

Fiber-Optic Systems

Connectors

Cables

Panels & Patchbays

Multichannel Systems

Cable Assemblies

Fiber - Optic Systems

Mux/Demux, Splitter

CWDM Mux/Demux

Slot-in Module Types

Model	Ch.	Wavelengths	Occupancy
FCWDM - 8B	8	1471 - 1611 nm	8 slots
FCWDM - 8B - 13	8	1271 - 1451 nm	

Rack Mount Types

Model	Ch.	Wavelengths	Size
FCWDM8/1A	8	1471 - 1611 nm	1RU
FCWDM8/1A - 13	8	1271 - 1451 nm	
FCWDM8/2A	2 each of 8	2 each of 1471 - 1611 nm	
FCWDM8/2A - 13	2 each of 8	2 each of 1271 - 1451 nm	
FCWDM16A	16	1271 - 1611 nm	

Key Features and Benefits

- Bi-directional 8 or 16 wavelengths.
- Passive and stand-alone products.
- Easy to use - Just plug in SC-type connectors.
- FCWDM-8B(-13) can be loaded into 161UPSC; enables 8-wavelength CWDM within 1RU frame.

<Loading example (rear view of 161UPSC)>

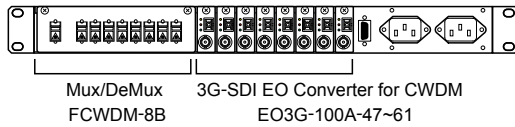

Specifications

Model	FCWDM - 8B (-13)	FCWDM8/1A (-13)	FCWDM8/2A (-13)	FCWDM16A
Connectors	SC			
Passband	+/- 6.5 nm (ITU-T G.695)			
Min. Passband Ripple	0.5 dB			
Max. Insertion Loss*	2.0 dB			3.3 dB
Min. Isolation	30 dB			
Dimensions (mm)	146 × 43.4 × 94.2	482.6 × 44 × 362.3		
Weight (approx.)	210 g	1700 g	1800 g	1890 g
Wavelengths Details (nm)	1271 - 1451: 1271/1291/1311/1331/1351/1371/1431/1451 1471 - 1611: 1471/1491/1511/1531/1551/1571/1591/1611			

* Insertion loss includes ripple, PDL, and connector loss



FCWDM-8B



FCWDM8/1A (Rear View)



FCWDM8/2A (Rear View)



FCWDM16A (Rear View)



Optical Splitter

Model	Wavelength	Description
FDM - 2	1261 - 1611nm	1 × 2 Splitter for Single Mode Fiber
FDM - 4		1 × 4 Splitter for Single Mode Fiber

Key Features and Benefits

- Divides single optical input into multiple optical output.
- Passive and stand-alone products.
- Can be loaded into platform for Canare plug-in unit.
- Easy to use - Just plug in SC-type connectors.
- Low insertion loss.

Insertion Loss

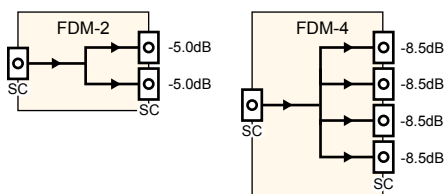

FDM-2

Slot Occupancy: 3 slots
Dimensions: 54 × 43.4 × 82 mm
Weight: 83g



FDM-4

Slot Occupancy: 4 slots
Dimensions: 72 × 43.4 × 82 mm
Weight: 110g

Platform

Power supply for Canare plug-in modules. The robust 1RU rack mountable and space efficient portable types are available.

Model	Description	Number of Slots
161UPSC-**	1RU rack mount type	16
6PSC-**	Portable type	6
2PSC	Palm size	2
PSM2-**	Redundant power supply module for 161UPSC	N/A

Note: 161UPSC shall be used in countries where CE marking directive is not applied. Contact Canare for details.

Key Features and Benefits

- Compact design - Maximum 16 modules within 1RU
- Hot swappable
- 161UPSC can be output 4 types of alarm signals via Dsub 9P (F).
- 161UPSC provides power redundancy by adding a PSM2.

Specifications

Model	161UPSC	6PSC	2PSC
Number of Slots	16	6	2
AC Input Voltage	100 to 240V 50/60Hz 0.35A		N/A
DC Input Voltage	N/A	10 to 18V	10 to 18V
Max Power Consumption (exclusive of modules)	22W	4.5W (AC) 2.2W (DC)	2.2W
Power Connector	AC3P Jack	AC3P Jack (AC) XLR4 Male (DC)	XLR4 Male
Supply Voltage to Module	DC 5V		
Operating Temperature	- 10 to 40 deg C		



161UPSC-**
Dimensions: 434 × 44 × 340 mm
Weight: 4500g



6PSC-**
Dimensions: 210 × 44 × 165 mm
Weight: 650g



2PSC
Dimensions: 90 × 44 × 110 mm
Weight: 200g

10- slot portable platform is also available.



10PSA-JP
Dimensions: 210 × 44 × 280 mm
Weight: 1200 g

Stand Alone Kit New

Model	For	Description
WMM0190	TRM with power input (TRM- 100/230/400/540)	a clamping bracket (one side)
WEPZ0258		AC 100 -240V to DC 5V adapter, Plug Type A No CE marking

Key Features and Benefits

- Operates a TRM converter without a Platform.
- Simple and cost-effective method
- Used in combination of two WMM0190 and WEPZ0258.



WMM0190



2 of WMM0190 with TRM



WEPZ0258

Technical Trend
Fiber-Optic Systems
Connectors
Cables
Panels & Patchbays
Multichannel Systems
Cable Assemblies

Fiber - Optic Systems

HFO Transmission Devices

HFO Transmission Device (Quad-link)

Transmit 4-channel SDI over a HFO camera cable.

■ **FCBK4-12G** **12G-SDI** **New** Support 12G/6G/3G/HD/SD-SDI and DVB-ASI

Model	HFO Connector	EO/OE Modules	EXT Connector	IDX V-plate
FCBK4-FF5W1-12G	FCFRA (Female)	4 × OE12G-101B (RX)	XLR5 Female	No
FCBK4-FF5W1-12G-PV	FCFRA (Female)	4 × OE12G-101B (RX)	XLR5 Female	Yes
FCBK4-FM5W2-12G	FCMRA (Male)	4 × EO12G-100A-** (TX)	XLR5 Male	No
FCBK4-FM5W2-12G-PV	FCMRA (Male)	4 × EO12G-100A-** (TX)	XLR5 Male	Yes

FCBK4-FM5W2-12G



FCBK4-FF5W1-12G

■ **FCBA4-3G** Support 3G/HD/SD-SDI and DVB-ASI

Model	HFO Connector	EO/OE Modules	EXT Connector	IDX V-plate
FCBA4-FF5W1	FCFRA (Female)	4 × OE3G-101 (RX)	XLR5 Female	No
FCBA4-FF5W1-PV	FCFRA (Female)	4 × OE3G-101 (RX)	XLR5 Female	Yes
FCBA4-FM5W2	FCMRA (Male)	4 × EO3G-100A-** (TX)	XLR5 Male	No
FCBA4-FM5W2-PV	FCMRA (Male)	4 × EO3G-100A-** (TX)	XLR5 Male	Yes



(rear view)

Key Features and Benefits

- All-in-one device which combines four EO/OE modules and a power supply unit.
- The best solution for Quad-link 12G/3G-SDI outside broadcasting.
- Flexible configuration by replacing EO/OE modules.
- AC and DC input redundancy
- Optical SC connector for optional use

* Canare OC series (Hybrid-OPS profile) is also available. Please contact us for more details.

Specifications

Type	without V-plate	with V-plate
SDI connector	4 × 75Ω BNC	
Optical connector	SC (for optional use)	
AC input	AC 3P Jack	
DC input	XLR4-32-F77 (Male)	
Power requirement	AC 100-240 V, DC 10-18 V	
Operating Temp.	-10 to 40 deg C	
Dimensions	210 × 42 × 240 mm	
Weight	1800 g	1850 g

FCBA4-FM5W2



FCBA4-FF5W1



FCBA4-FM5W2-PV

<Example of Use>

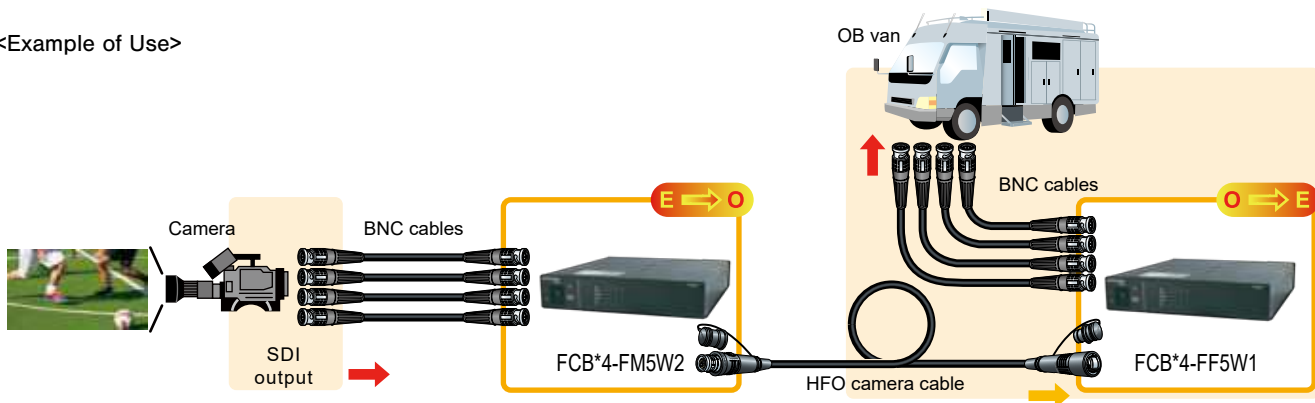

HFO Transmission Device (Bi-directional)

Transmit 2-channel SDI over a HFO camera cable.

■ **FCBK-12G** **12G-SDI** **New** Support 12G/6G/3G/HD/SD-SDI and DVB-ASI

Model	HFO Connector	EO/OE Modules	EXT Connector	IDX V-plate
FCBK-FF3W1-12G	FCFRA (Female)	EO12G-100B (TX) OE12G-101B (RX)	2 × XLR3 Female	No
FCBK-FF3W1-12G-PV	FCFRA (Female)	EO12G-100B (TX) OE12G-101B (RX)	2 × XLR3 Female	Yes
FCBK-FM3W2-12G	FCMRA (Male)	OE12G-101B (RX) EO12G-100B (TX)	2 × XLR3 Male	No
FCBK-FM3W2-12G-PV	FCMRA (Male)	OE12G-101B (RX) EO12G-100B (TX)	2 × XLR3 Male	Yes

FCBK-FM3W2-12G



FCBK-FF3W1-12G

■ **FCBA-3G** Support 3G/HD/SD-SDI and DVB-ASI

Model	HFO Connector	EO/OE Modules	EXT Connector	IDX V-plate
FCBA-FF3W1-3G	FCFRA (Female)	EO3G-100 (TX) OE3G-101 (RX)	2 × XLR3 Female	No
FCBA-FF3W1-3G-PV	FCFRA (Female)	EO3G-100 (TX) OE3G-101 (RX)	2 × XLR3 Female	Yes
FCBA-FM3W2-3G	FCMRA (Male)	OE3G-101 (RX) EO3G-100 (TX)	2 × XLR3 Male	No
FCBA-FM3W2-3G-PV	FCMRA (Male)	OE3G-101 (RX) EO3G-100 (TX)	2 × XLR3 Male	Yes



(rear view)

Key Features and Benefits

- All-in-one device which combines two EO/OE modules and a power supply unit.
- Ideal for outside broadcasting.
- Flexible configuration by replacing EO/OE modules.
- AC and DC input redundancy

* Canare OC series (Hybrid-OPS profile) is also available. Please contact us for more details.

■ **Specifications**

Type	without V-plate	with V-plate
SDI connector	2 × 75Ω BNC	
AC input	AC 3P Jack	
DC input	XLR4-32-F77 (Male)	
Power requirement	AC 100-240 V, DC 10-18 V	
Operating Temp.	-10 to 40 deg C	
Dimensions	210 × 42 × 240 mm	
Weight	FCBK-12G	1400 g
	FCBA-3G	1200 g

FCBA-FM3W2-3G



FCBA-FF3W1-3G



FCBA-FM3W2-3G-PV

<Example of Use>

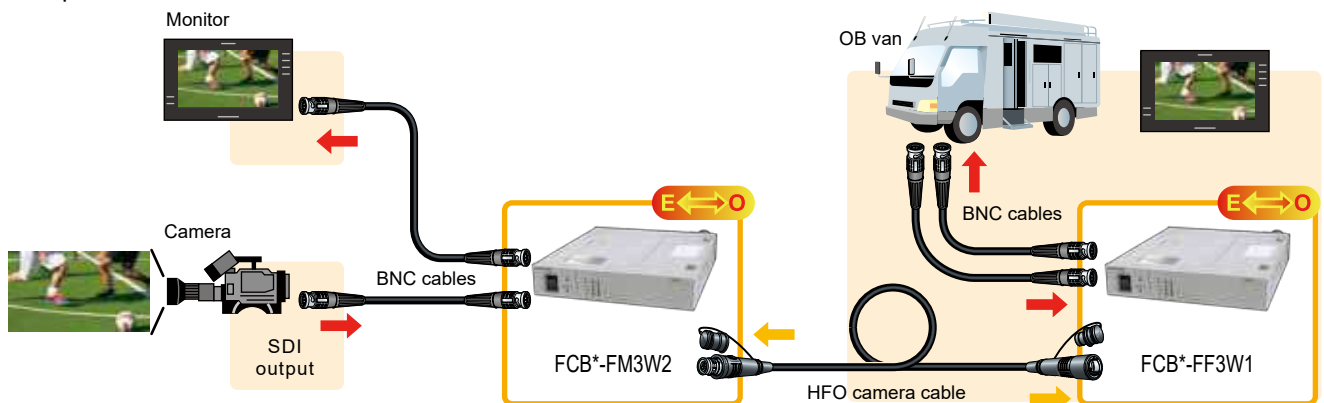

Fiber - Optic Systems

HFO Camera Cables

Hybrid Fiber-optic Camera Cables (SMPTE ST 311)

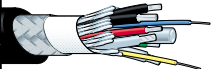
Type	Model	Sales Units (m)	Nom. O.D. (mm)	Weight kg/100m	Outer Jacket	Overall Shield	Tension Tolerance (N)	Strength Member O.D. (mm)	Min. Bend Radius	Temp. Range (deg C)	Channel Unit		
											Fiber	Aux. (Power)	Signal (Control)
 LF-2SM9N Jacket color: BLK	LF-2SM9N	Call	9.2	12.0	Abrasion-resistance PVC	9/24/0.10TA 91%	700	2.6	6 × Nom. O.D.	-40 to +75	2 × SM 9/125 (low-water-peak) Unit O.D. 0.9 mm	4 × 20 AWG 21 / 0.18TA Unit O.D. 1.7 mm	2 × 25 AWG 7 / 0.18TA Unit O.D. 1.2 mm
	LF-2SM16		16	29.0	Double PVC								

LF-2SM9N

- For general use.
- Abrasion-resistance Jacket enhance the adaptability to all studio and outside broadcast applications.
- Cost effective



LF-2SM16

- For studio use.
- O.D. 16mm Double Jacket prevents the cable from being jammed under a camera pedestal dolly.

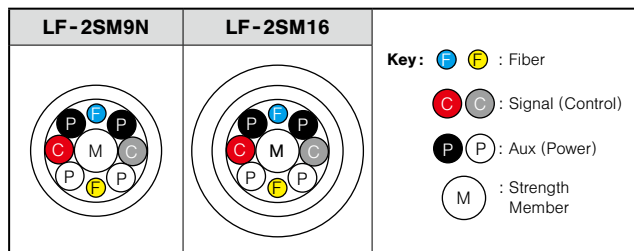
Cross Section



Camera to CCU

Type	Model	Length (m)
 LF-2SM9N Jacket color: BLK	FCC10N	10
	FCC20N	20
	FCC25N	25
	FCC35N	35
	FCC50N	50
	FCC100N	100
 LF-2SM16 Jacket color: BLK	FCC150N	150
	FCC200N	200
	FCC30A-WJ	30
	FCC50A-WJ	50
	FCC100A-WJ	100

- Standard and widely-used models.
- Heat shrink tubes help in labeling.
- FCC**A-WJ prevents the cable from being jammed under a camera pedestal dolly by its O.D. 16mm double jacket.
- 7-color connector rings included.

* Canare OC series (Hybrid-OPS profile) is also available. (see page 21)



FCFA



FCMA



Color Rings

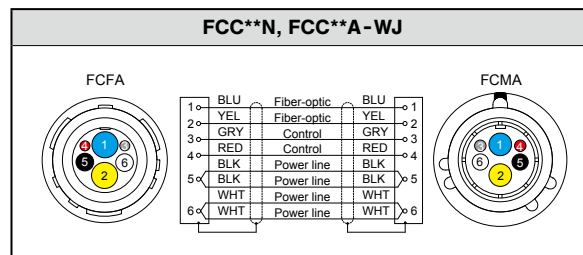

Wiring Diagram

HFO Protective Covers New

Any-time-fit-on protector for SMPTE connector - the new traditional

Model	Shape	Component	Color
FC-CV-F-SET-**	Female	1 × Boot	RD: Red GR: Green YL: Yellow BK: Black
FC-CV-M-SET-**	Male	1 × Holder	

Please specify the color such as FC-CV-F-SET-RD

Cover: PVC, Holder: PE

- Canare exclusive retrofittable construction (patent pending)
- Fit for Canare FC series and other SMPTE 304 plugs
- Heavy-duty and harsh environment applications
- Quality verified over shock resistance tests

* Not available for Canare OC series

* The male and female are for FCMA and FCFA or equivalent respectively.

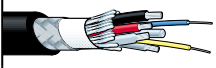

Slim Hybrid Fiber-optic Camera Cable

Type	Model	Sales Units (m)	Nom. O.D. (mm)	Weight kg/100m	Outer Jacket	Overall Shield	Tension Tolerance (N)	Strength Member O.D. (mm)	Min. Bend Radius	Temp. Range (deg C)	Channel Unit		
											Fiber	Aux. (Power)	Signal (Control)
	LF-2SM7N	Call	7.1	7.3	Abrasion-resistance PVC	8/24/0.10TA 91%	300	1.4	6 × Nom. O.D.	-40 to +75	2 × SM 9/125 (low-water-peak) Unit O.D. 0.9 mm	2 × 20 AWG 21 / 0.18TA Unit O.D. 1.7 mm	2 × 25 AWG 7 / 0.18A Unit O.D. 1.2 mm

Jacket color: **BLK**

LF-2SM7N

- O.D. 7 mm of slim profile and approx. 40% lighter than LF-2SM9N.
- Best fit for mobile applications.
- The power transmission distance is approx. twice as long as the previous model LF-2SM7R.

Note: The power transmission distance is shorter than typical HFO camera cables (approx. 50% of LF-2SM9N). Please contact us for more information.

Cross Section

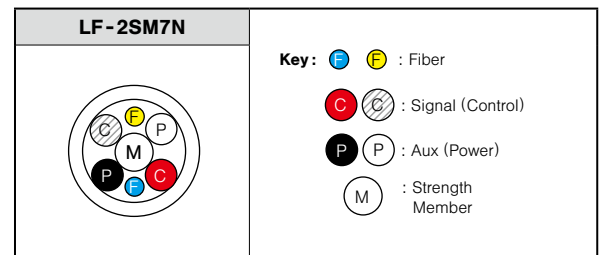

FCF7A



FCM7A



Color Rings

Camera to CCU

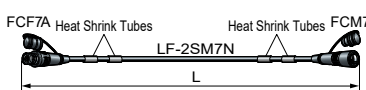
Type	Model	Length (m)
	FCC10-7N	10
	FCC20-7N	20
	FCC30-7N	30
	FCC50-7N	50
	FCC100-7N	100

Jacket color: **BLK**

- Equipped with slim and lightweight cable.
- FCC100-7N is approx. 5 kg lighter than typical 100m HFO camera cable as FCC100N.
- Heat shrink tubes help in labeling.
- 7-color connector rings included.

Note: The power transmission distance of FCC**-7N is approx. half of that of the FCC**N. * Canare OC series (Hybrid-OPS profile) is also available. (see page 21)

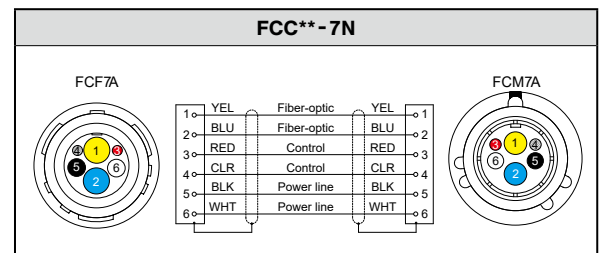

Wiring Diagram



FCC-7N**

Fiber - Optic Systems

HFO Camera Cables

Tough & Flexible HFO Camera Cables

Thermoplastic polyurethane type jacket offers amazing flexibility and superior mechanical properties; Crush Resistance, Impact Resistance and Cyclic Flexing exceed that of MIL.

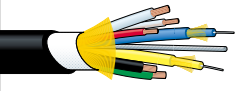
Type	Model	Sales Units (m)	Nom. O.D. (mm)	Weight kg/100m	Outer Jacket	Overall Shield	Tension Tolerance (N)	Strength Member O.D.	Min. Bend Radius	Temp. Range (deg C)	Channel Unit		
											Fiber	Aux. (Power)	Signal (Control)
 Jacket color: BLK DEEP RED DEEP GRN	LF-2SM9T	Call	9.2	9.8	TPU + PVC	N/A	1500	1.8 mm + Tensile strength fiber	Equal to Nom. O.D.	-40 to +75	2 x SM 9/125 (low-water-peak) Unit O.D. 0.9 mm	4 x 20 AWG 102 / 0.08A Unit O.D. 1.75 mm	2 x 25 AWG 24 / 0.08A Unit O.D. 1.2mm
 Jacket color: BLK	LF-2SM7T	Call	7.1	5.5	TPU + PVC	N/A	1000	0.63 mm + Tensile strength fiber	Equal to Nom. O.D.	-40 to +75	2 x SM 9/125 (low-water-peak) Unit O.D. 1.7 mm	2 x 23 AWG 60 / 0.08A Unit O.D. 1.4 mm	2 x 26 AWG 30 / 0.08A Unit O.D. 1.1 mm

LF-2SM9T

- Heavy-duty yet Flexible.
- Ideal for remote broadcast applications.
- Minimum bend radius: 9.2 mm.

LF-2SM7T



- Flexible, Slim, Lightweight, and moreover, Heavy-duty.
- Ideal for short-distance remote broadcast applications of up to 200 meters.
- O.D. 7.1 mm and weighing only 5.5 kg/100 m, it's so easy to carry around.
- Minimum bend radius: 7.1 mm.
- Fiber units include tensile strength fiber.

Note: The power supply distance of LF-2SM7T is shorter than other HFO camera cables. (approx. 30% of LF-2SM9N)
LF-2SM7T requires a special technique during a connector assembly, so you can buy the cable assemblies shown below.

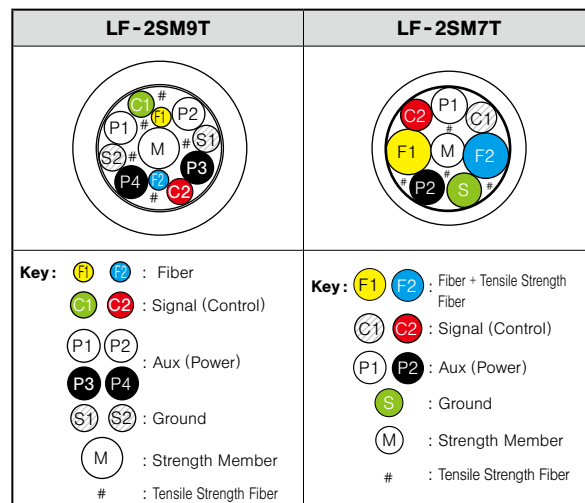
Cross Section



Camera to CCU

Type	Model	Length (m)
 Jacket color: BLK DEEP RED DEEP GRN	FCC10-9T	10
	FCC20-9T	20
	FCC25-9T	25
	FCC35-9T	35
	FCC50-9T	50
	FCC100-9T	100
 Jacket color: BLK	FCC150-9T	150
	FCC200-9T	200
	FCC10-7T	10
	FCC20-7T	20
	FCC30-7T	30
	FCC50-7T	50
	FCC100-7T	100

- Tough & Flexible cable
- Fit for mobile applications in harsh environments.
- Heat shrink tubes help in labeling.
- 7-color connector rings included.

Note: The power transmission distance of FCC**-7T is quite shorter than typical HFO camera cables.

* Canare OC seires (Hybrid-OPS profile) is also available. Please contact us for more details.



FCC-7T**



FCFA, FCF7A



FCMA, FCM7A



Color Rings

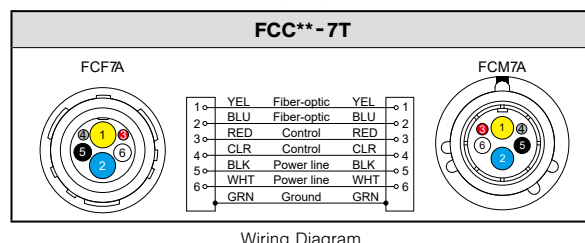
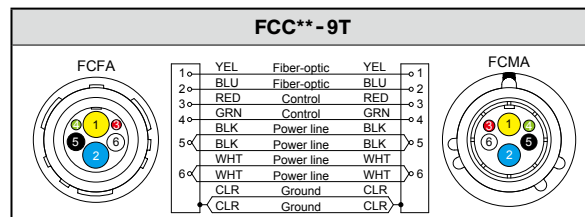

HFO Camera Cable Assemblies (Flanged Type)

Panel to CCU

Type	Model	Length (m)
	FCC05N - FRCM	5
	FCC10N - FRCM	10
Jacket color: BLK IU-FCF-SET included		
	FCC05N - FMRC	5
	FCC10N - FMRC	10
Jacket color: BLK IU-FCM-SET included		

* Canare OC series (Hybrid-OPS profile) is also available. (see page 21)

- HFO camera cable with the flange for panel mounting.
- SMPTE ST 304, ST 311, and ARIB BTA S - 1005B compliant.
- Return loss: 45dB or greater ($\lambda = 1.3\mu\text{m}$).
- Insertion loss: 0.5dB or less ($\lambda = 1.3\mu\text{m}$).
- Connector body material is stainless steel.
- Color rings and insulation plates included.
- See below for the panel hole dimensions.



FCFRCA



FCMRCA



Color Rings



IU-FC*-SET

HFO Camera Receptacle Cables

Pigtails

Type	Model	Length (m)
	FCS015A - FR	1.5
	Jacket color: BLK IU-FCF-SET included	
	FCS015A - MR	1.5
	Jacket color: BLK IU-FCM-SET included	

* Canare OC series (Hybrid-OPS profile) is also available. (see page 21)

- Ideal for connecting wall terminal panels to splice enclosures, etc.
- Return loss: 45dB or greater ($\lambda = 1.3\mu\text{m}$).
- Insertion loss: 0.5dB or less ($\lambda = 1.3\mu\text{m}$).
- Connector body material is stainless steel.
- Insulation plates included.
- See below for the panel hole dimensions.



FCFRCA



FCMRCA

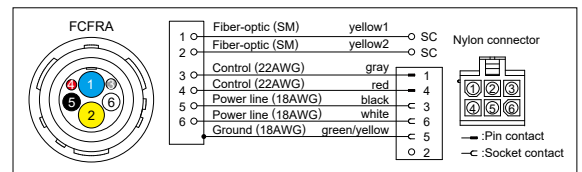

Wiring Diagram

Insulation Plate

Ideal for perfect insulation between individual connector and panel.

Model	Suitable Connector
IU-FCM-SET	FCMRA, FCMRCA
IU-FCF-SET	FCFRA, FCFRCA

- Material: Bakelite (phenolic resin)
- Mounting screws included.

Extraction Tool

Extraction tool helps easy to clean Canare HFO connectors.

Model	Suitable Connector
ASPT-1	FCFA, FCF7A, FCFRA, FCFRCA

- Tool to be used to release the alignment sleeve unit when cleaning HFO connectors.

* Use the CLETOP 2.5/2.0 (100) cleaning stick to clean fiber-optic camera connectors.



IU-FC*-SET

Hole Dimensions

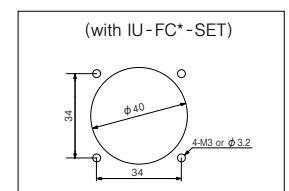

ASPT-1



Quick-release

US Patent No.7241055B2
JP Patent No.4340186

Fiber - Optic Systems

HFO Camera Cables

HFO Camera Cable Assemblies (Japanese Style)

Canare OC hybrid camera connectors are commonly used in Japan and Asian countries. It includes the same combination of SMPTE 304 but different pinouts. Improved reliabilities and advanced maintenance features.



OC connectors

- Symmetric pinout
- Finger detachable insulator
- Better grip, proper connections
- SMPTE 311 cable ready
- Camera MFGs accepted
- Hybrid-OPS profile



FC connectors

- SMPTE and ARIB standard
- Detachable insulator with tool
- Widely used in the market
- Hybrid-3K profile

Camera to CCU

OCC100-N

Series name

Cable mount plugs
Male and female

Lengths

01 = 1 meters
100 = 100 meters
Call for stocked lengths.

Cable type

N : LF-2SM9N O.D. 9 mm PVC Jacket (most common)
WJ : LF-2SM16 O.D. 16 mm PVC Jacket
7N : LF-2SM7N O.D. 7 mm PVC Jacket
9T : LF-2SM9T O.D. 9 mm TPU Jacket w/o Shield
7T : LF-2SM7T O.D. 7 mm TPU Jacket w/o Shield
TPU = Thermoplastic Polyurethane



OCFA



OCMA

Panel to CCU

OCC05N-FRCM

Series name

PNL mount M to
cable mount F
and vice versa

Lengths

05 = 5 meters
10 = 10 meters
Call for custom lengths.

Connector type

FRCM : OCFCRB-OCMA
FMRC : OCMRCA-OCFA

Cable type: LF-2SM9N



OCFCRB



OCMRCA

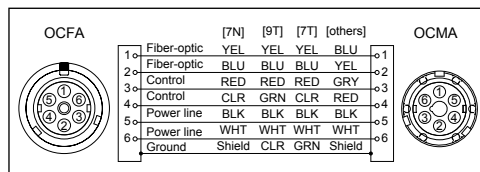

Wiring Diagram for OCC

Pigtails

OCS015-FR

Series name

OC breakout

Lengths

015 = 1.5 meters
Call for custom lengths.

Connector type

FR : OCFA to 2 × SC, 1 × Nylon
MR : OCMRA to 2 × SC, 1 × Nylon

SMPTE Conversion

FCM02N-OCF

Connector A

FCM : FCMA
FCF : FCFA

Lengths

02 = 2 meters
Call for custom lengths.

Connector B

OCF : OCFA
OCM : OCMA

Cable type: LF-2SM9N
Call for custom models.



OCS015-FR

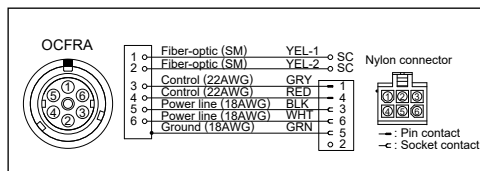

Wiring Diagram for OCS



FCF02N-OCM

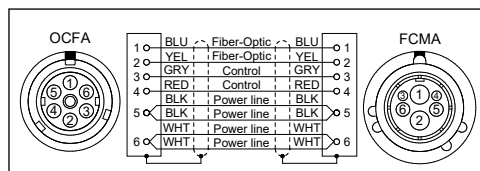

Wiring Diagram for Conversion

Hybrid Fiber-Optic Camera Cable Checker

Canare Cable Checker allows fast, easy confirmation of HFO cables in the field. No heavy equipment to drag around. The compact design features a backlight digital display to measure optic loss/power and electrical continuity. Small and light, Canare Cable Checker helps make mobile installations smooth, secure and constant.

Kit Model	Individual Model	
	Measuring Unit	Loop-back Unit
FCT-FCKIT RED	FCT-FC RED	FCT-FCLB RED
FCT-OCKIT RED	FCT-OC RED	FCT-OCLB RED

Key Features and Benefits

- Check hybrid camera cables instantly
- Indicating optic power and loss, electrical open-circuit and short-circuit at the same time
- Available in two most common hybrid camera connector interfaces
- All-in-one kit includes storage box, leather case, AA batteries, and CLETOP

Specifications

Kit Model	FCT-FCKIT RED	FCT-OCKIT RED
Connector	Canare FC series (SMPTE/ARIB)	Canare OC series (Hybrid-OPS)
LD	FP-LD	
Wavelength	1310 nm	
Output Power	-2.5 dBm	
Sensitivity	-24 to -2 dBm	
Maximum Length	3.5 km (Canare LF-2SM9N)	
Optic Signals	Optical Power and Loss	
Electric Signals	Open-circuit and Short-circuit	
Battery/Life	2 pcs of AA/ Approx. 20hours	
Operating Temperature	-10 to 60 deg C	
Dimensions	Measuring Unit: 46 × 46 × 150 mm Loop-back Unit: 46 × 46 × 65 mm	
Weight	Measuring Unit: 380 g Loop-back Unit: 170 g	
Accessories	Storage case, carrying cases, AA Batteries, and cleaning sticks	

Note: Red cap model will not work with black cap model.

CE, FCC, FDA registered
US Patent No.7113678
JP Patent No.4155979



Carrying Cases

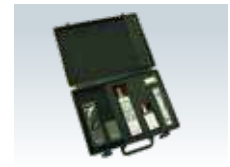

Storage Case

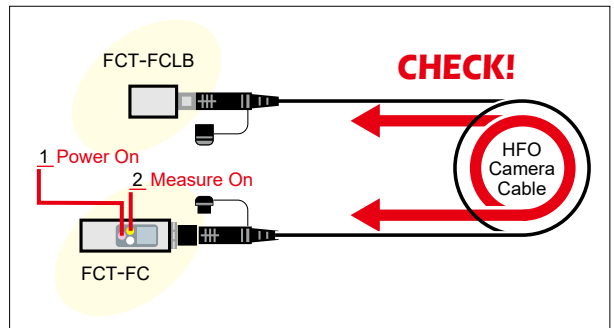

⚠ To prevent the product from being damaged, please NOTE the following points before connection:

- A) Discharge static electricity from HFO camera cable by grounding its metal part.
- B) Connect the Loop-back Unit first.
- C) Do not connect anything other than the Cable Checker and HFO camera cable.

Technical Note

Maintaining Hybrid Fiber-Optic Camera Connectors

The connector sections to be cleaned are the key parts, including the tips and sides of ferrules, the interior walls of alignment sleeves and the interior and exterior of connector shells. Note that scratches and particles of foreign matter on the tip of the ferrule can have a disabling effect on fiber-optic transmission. The following procedures should be used when cleaning hybrid fiber-optic camera connectors.

- For Plugs, the interior surfaces of alignment sleeves and the tips of ferrules are to be cleaned with the non-alcohol treated cleaning stick using a gentle stroking action. Canare FCFA and FCFRA enhance easy cleaning procedure for its innovative alignment sleeve and insulator detachable design. US Patent: No.7241055B2, JP Patent: No.4340186
- For Jacks, it is important to clean both the tips and sides of the completely protruding ferrules with the cleaning stick.
- Both the male and female connector shells tend to attract dust and metal particles, so it is important to clean both the insides and outsides using cotton gauze or similar material.

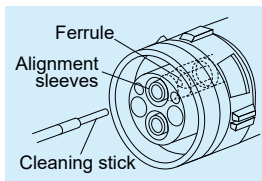

Before cleaning



After cleaning

Cleaning Stick Model: CLETOP 2.5/2.0

- Compact and disposable
- Allows cleaning both the tips and sides of ferrules
- Manufactured by NTT-AT



Cleaning stick CLETOP 2.5/2.0

IBC Brand Cleaner M-20 Model: 14347 CLEANER

- Easy "one-push" cleaner
- Allows cleaning the tips of ferrules without removing alignment sleeve
- Manufactured by US Conec



IBC Brand Cleaner M-20 14347 CLEANER

Fiber - Optic Systems

HFO Camera Connector Panels

Hybrid Fiber-optic Camera Connector Panels

Pre-terminated HFO camera connector panel with built-in splice enclosure box provides easy and quick installation between HD camera system and terminal panel or rack. By combining the unit and frame, HFO camera connector panel enables a variety of layouts depending on the system design.

■ COPS Series (SMPTE)

Model	Panel Size	HFO Connectors* (Assembly)
COPS-FF3A	Wall Mount Type 3RU Height, W: 197.6mm	2 × FCFRA (FCS003A-FR)
COPS-FM3A		2 × FCMRA (FCS003A-MR)
COPS-FF2A	Wall Mount Type 2RU Height, W: 197.6mm	2 × FCFRA (FCS003A-FR)
COPS-FM2A		2 × FCMRA (FCS003A-MR)
COPS3-FF3A	Rack Mount Type 3RU	6 × FCFRA (FCS003A-FR)
COPS3-FM3A		6 × FCMRA (FCS003A-MR)
COPS3-FF2A	Rack Mount Type 2RU	6 × FCFRA (FCS003A-FR)
COPS3-FM2A		6 × FCMRA (FCS003A-MR)

*HFO connectors are pre-terminated. (length: 0.3 m)

*Canare OC series (Hybrid-OPS profile) is also available. Please contact us for more details.

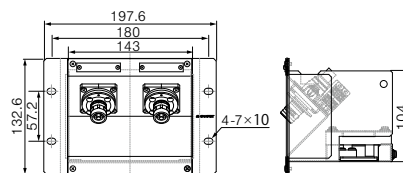

COPS-FF3A

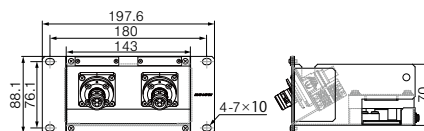

COPS-FF2A

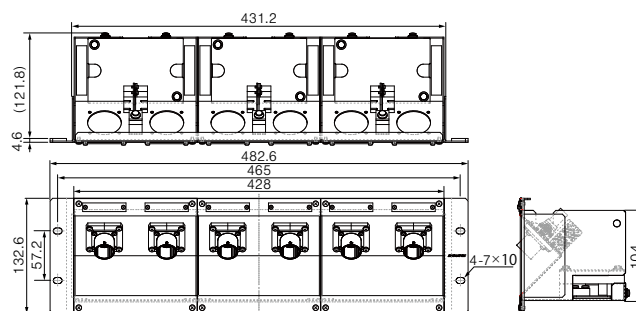

COPS3-FM3A

Key Features and Benefits

- Exclusive "5-directional Wiring"
- Convenient to build I/O interface between HD facilities and HD OB vans
- Variety of choice of 2RU/3RU and wall/rack mount
- Pre-terminated HFO connectors reduce installation time dramatically.
- Cost effective
- Lightweight aluminum chassis

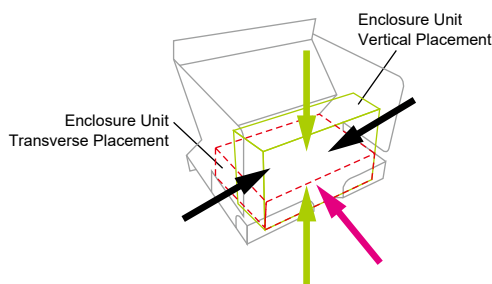

5 directions of cabling as indicated by colored arrows

- Vertical/Transverse placement
- Transverse placement
- Vertical placement

5-directional Wiring
JP Patent No.4388540

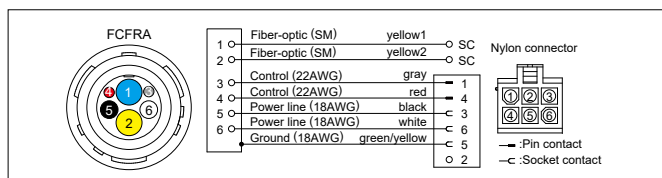

Wiring Diagram

Accessories:
Fiber-optic cable w/SC connector (2m), grounding cable, nylon connector, pin contact, socket contact, tie-band, fusion splice protection sleeve, splice holder, color-coded tube, mounting screw, laser warning label.

Note: Assembly tools for the nylon connectors are NOT include.
(AMP 91529-1: 26 to 22 AWG and AMP 91536-1: 20×2 to 16 AWG)

Individual Frame and Unit

Model	Height	Description
COUS-FF3A	3RU	Connector Unit of COPS(3)-FF3A
COUS-FM3A		Connector Unit of COPS(3)-FM3A
COF-13C		Frame of COPS (for 1 unit)
COF-33B	2RU	Frame of COPS3 (for 3 units)
COUS-FF2A		Connector Unit of COPS(3)-FF2A
COUS-FM2A		Connector Unit of COPS(3)-FM2A
COF-12B		Frame of COPS (for 1 unit)
COF-32A	Frame of COPS3 (for 3 units)	

*HFO connectors are pre-terminated. (length: 0.3 m)
 *Canare OC series (Hybrid-OPS profile) is also available. Please contact us for more details.

Optional Parts

Model	Type	Suitable Frame/Unit
COU-BP3A	Blank Panel	COF-13A, COF-33B (3RU frames)
COU-BP2A		COF-12A, COF-32A (2RU frames)
COU-CV3	Top Cover	COUS-FF3A, COUS-FM3A (3RU units)
COU-CV2		COUS-FF2A, COUS-FM2A (2RU units)

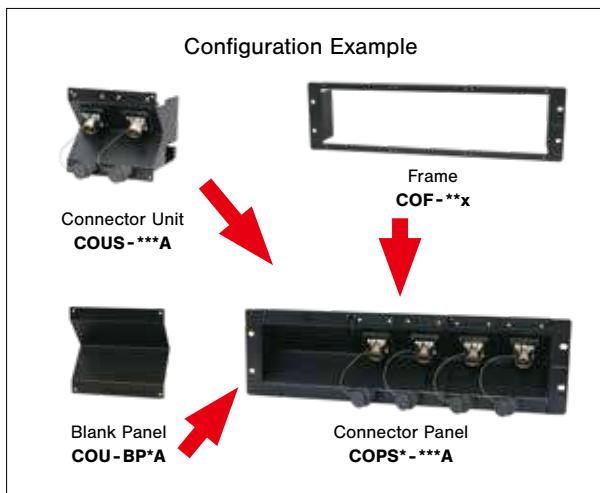

Example of Use

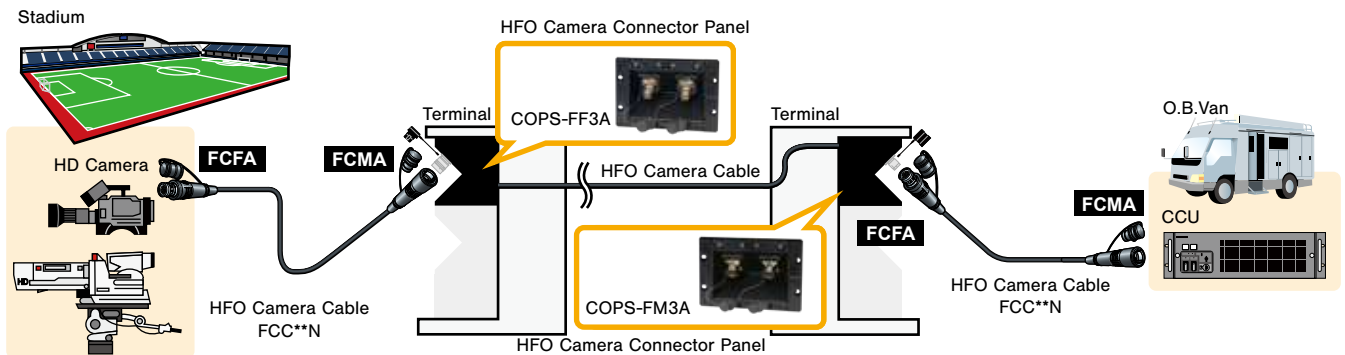

Hybrid Fiber-optic Splice Enclosures

The optimized fiber-optic splice enclosures for use with HFO camera cables.

Model	No. of cables (capacity)	No. of splice trays	No. of Adapters	
			SC	Nylon
FCE-2	2	1	4	2
FCE-4	4	2	8	4
FCE-6	6	3	12	6

- Used to protect fusion splice connection parts
- Designed for use with LF-2SM9N
- Easy cable installation
- Can be placed vertically or horizontally
- Detachable brackets and a connector protection cover
- Insulated tension member clamp

Note :
 The following tools are required for installing the nylon connector.
 AMP 91529-1 (26 to 22 AWG) and AMP 91536-1 (20 × 2 to 16 AWG)

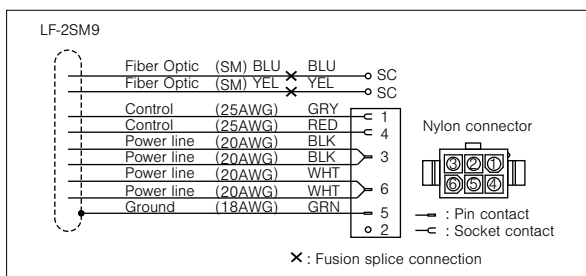

Wiring Diagram



FCE-2

Accessories:
 Fiber-optic cable w/SC connector (2m), splice holder, fusion splice protection sleeve, nylon connector, pin contact, socket contact, tie band, grounding cable, color-coded tube.

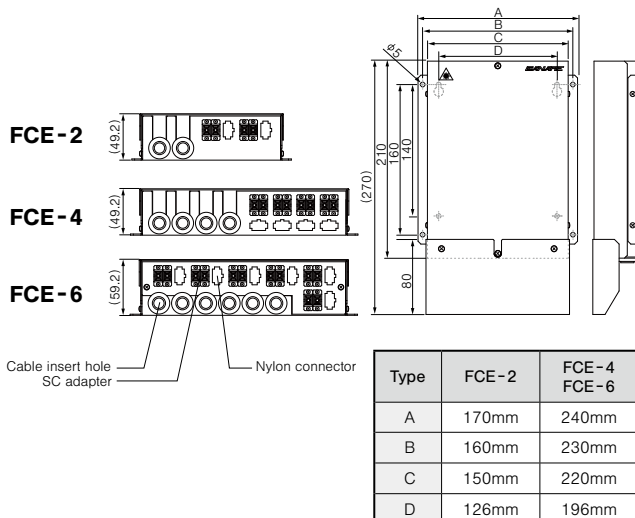

Fiber - Optic Systems

Fiber - optic Cables

6 - channel Fiber - optic Snakes

Type	Model	Length (m)
	OM6C10	10
	OM6C20	20
	OM6C25	25
	OM6C35	35
	OM6C50	50
	OM6C100	100
	OM6C150	150
	OM6C200	200

Jacket color: **BLK**

- Ruggedized multichannel fiber-optic assemblies with robust 6-fiber connector
- Single-mode, ITU-T G.657.A2 low bending loss and low water-peak fiber
- Abrasion-resistance cable jacket
- Tensile strength: 700 N or less
- Return loss: 45 dB or greater ($\lambda = 1.3 \mu\text{m}$)
- Insertion loss: 0.5 dB or greater ($\lambda = 1.3 \mu\text{m}$)
- 7-color connector rings included.
- Blue dust cap makes it easier to distinguish OM6 from HFO camera connectors.



- * Canare OM6 connectors are NOT compatible with other multichannel/hybrid fiber-optic connectors.
- * IBC brand "one-push" cleaner M-20 is highly recommended for cleaning OM6 connectors. (see page 22, model: 14347 CLEANER)



OM6PA



OM6JA



Color Rings

6 - channel Fiber - optic Fantails

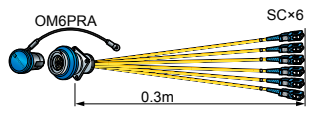
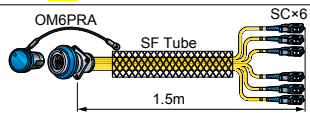
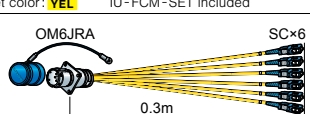
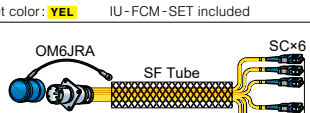
Type	Model	Length (m)
 <p>Jacket color: YEL IU-FCM-SET included</p>	OM6S003-PR	0.3
 <p>Jacket color: YEL IU-FCM-SET included</p>	OM6S015-PR	1.5
 <p>Jacket color: YEL IU-FCM-SET included</p>	OM6S003-JR	0.3
 <p>Jacket color: YEL IU-FCM-SET included</p>	OM6S015-JR	1.5

- OM6 receptacle with 6 SC single-mode fiber cord (2.0mm).
- Return loss: 45 dB or greater ($\lambda = 1.3 \mu\text{m}$)
- Insertion loss: 0.5 dB or greater ($\lambda = 1.3 \mu\text{m}$)
- Blue dust cap makes it easier to distinguish OM6 from HFO camera connectors.

- * Canare OM6 connectors are NOT compatible with other multichannel/hybrid fiber-optic connectors.
- * IBC brand "one-push" cleaner M-20 is highly recommended for cleaning OM6 connectors. (see page 22, model: 14347 CLEANER)



OM6PRA



OM6JRA

■ Hole Dimensions

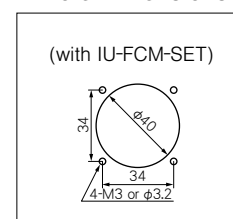

Tactical Fiber-optic Cable

Particularly rugged multichannel fiber-optic cable designed for mobile applications.

Type	Model	No. of Ch.	Sales Units (m)	Nom. O.D. (mm)	Weight kg/100m	Tension Tolerance (N)	Strength Member	Min. Bend Radius	Temp. Range (deg C)	Fiber-optic Unit		
										Fiber	Attenuation	Unit O.D.
	LF-SM2T-4C	4	100 200 500	7.8	4.9	1400	Aramid yarn	Equal to Nom. O.D.	-55 to +85	SM 9/125 (low-water-peak)	1.6 dB/km @1310 nm	2.0 mm including aramid yarn

Jacket color: **BLK**

Jacket: TPU



LF-SM2T-4C

- Heavy-duty and high flexibility
- * Crush resistance : 2,000 N/cm
- * Impact resistance : 300 impacts
- * Cycle flexing : 20,000 cycles
- Single-mode
- Color-coded breakout type unit
- Thermoplastic polyurethane jacket
- Aramid yarn strength member
- 4-channel cable best suited for Quad-link 3G-SDI signals.

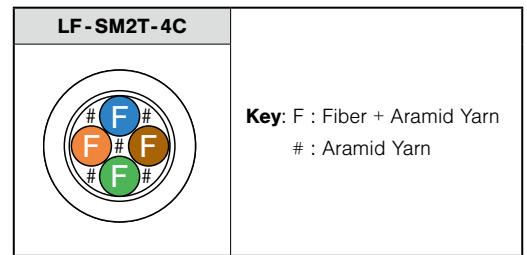
Cross Section

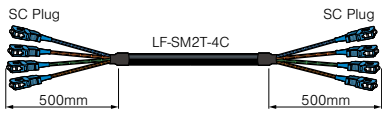

Cable Assemblies

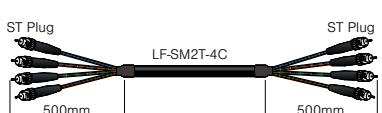
Type	Model	Length (m)
 Jacket color: BLK	4FS50T-SS	50
	4FS100T-SS	100
	4FS150T-SS	150
	4FS200T-SS	200
 Jacket color: BLK	4FS50T-LS	50
	4FS100T-LS	100
	4FS150T-LS	150
	4FS200T-LS	200
 Jacket color: BLK	4FS50T-ST	50
	4FS100T-ST	100
	4FS150T-ST	150
	4FS200T-ST	200

Single-mode Fiber-optic Cables (Multichannel)

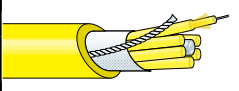
Type	Model	No. of Ch.	Sales Units (m)	Nom. O.D. (mm)	Weight kg/100m	Outer Jacket	Tension Tolerance (N)	Min. Bend Radius	Temp. Range (deg C)	Fiber-optic Unit		
										Fiber	Attenuation	Unit O.D.
 LF-SM2-6C Jacket color: YEL	LF-SM2-2C	2	Call	7.4	5.4	PVC	290	10 x Nom. O.D.	-40 to +75	SM 9/125 + Aramid yarn + PVC jacket	0.5 dB/km @1310nm	2.0 mm including aramid yarn
	LF-SM2-4C	4		7.4	5.5		290					
	LF-SM2-6C	6		9.0	7.3		300					
	LF-SM2-8C	8		10.0	10.4		780					
	LF-SM2-12C	12		12.8	14.2		780					
	LF-SM2-16C	16		14.7	16.3		780					
	LF-SM2-24C	24		15.0	18.3		780					

- Smooth PVC Jacket
- Including a central strength member and a rip cord.

Fiber - Optic Systems

Fiber-optic Cables

Single-mode Fiber Optic Patch Cables

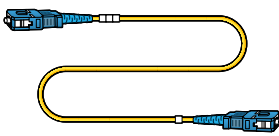
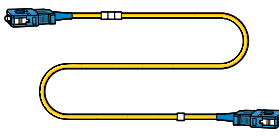
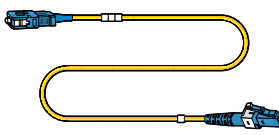
Type	Model	Length (m)
SC - SC 	FS3C002A - S	0.2
	FS3C003A - S	0.3
	FS3C005A - S	0.5
	FS3C007A - S	0.7
	FS3C01A - S	1
SC - SC 	FS2C002A - SS	0.2
	FS2C003A - SS	0.3
	FS2C005A - SS	0.5
	FS2C007A - SS	0.7
	FS2C01A - SS	1
SC - LC 	FS2C002A - SS/LS	0.2
	FS2C003A - SS/LS	0.3
	FS2C005A - SS/LS	0.5
	FS2C007A - SS/LS	0.7
	FS2C01A - SS/LS	1

Jacket color: **YEL** Cable O.D.: 3 mm

Jacket color: **YEL** Cable O.D.: 2 mm

Jacket color: **YEL** Cable O.D.: 2 mm

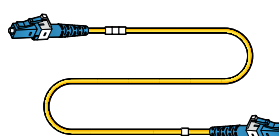
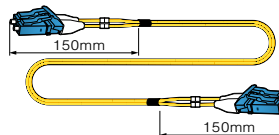
Type	Model	Length (m)
LC - LC 	FS2C002A - LS	0.2
	FS2C003A - LS	0.3
	FS2C005A - LS	0.5
	FS2C007A - LS	0.7
	FS2C01A - LS	1
LC - LC Duplex 	2FSZ2S005A - DLS	0.5
	2FSZ2S007A - DLS	0.7
	2FSZ2S01A - DLS	1
	2FSZ2S02A - DLS	2
	2FSZ2S03A - DLS	3

Jacket color: **YEL** Cable O.D.: 2 mm

Jacket color: **YEL** Cable O.D.: 2 mm

- ITU-T G.652.D/G.657.A2
- Low - water - peak
- Minimum bend radius : 10 mm
- Insertion loss : 0.5 dB max.
- Return loss : 50 dB max. (UPC)
- UL type OFNR

Single-mode Fiber Optic Fantails

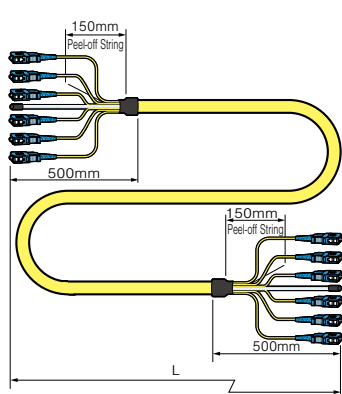
Type	Channel	Model	Length (m)	Fiber Optic Cable		
				Part Number	Unit O.D. (mm)	Nom. O.D. (mm)
SC - SC 	2	2FS10 - S	10	LF-SM2-2C	2	7.4
		2FS20 - S	20			
		2FS50 - S	50			
	4	4FS10 - S	10	LF-SM2-4C		7.4
		4FS20 - S	20			
		4FS50 - S	50			
	6	6FS10 - S	10	LF-SM2-6C		9.0
		6FS20 - S	20			
		6FS50 - S	50			
	8	8FS10 - S	10	LF-SM2-8C		10.0
		8FS20 - S	20			
		8FS50 - S	50			
12	12FS10 - S	10	LF-SM2-12C	12.8		
	12FS20 - S	20				
	12FS50 - S	50				
16	16FS10 - S	10	LF-SM2-16C	14.7		
	16FS20 - S	20				
	16FS50 - S	50				
24	24FS10 - S	10	LF-SM2-24C	15.3		
	24FS20 - S	20				
	24FS50 - S	50				

Jacket color: **YEL**

- Flexible cable with reliable bellcore boots
- Adjustable fantail length with peel-off string
- UPC polishing; Return loss ≥ 50 dB for single mode
- Transmission loss 0.5dB at $\lambda = 1.31\mu\text{m}$ and 0.4dB at $\lambda = 1.55\mu\text{m}$

OM3 Multi-mode Fiber Optic Patch Cables

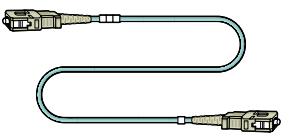
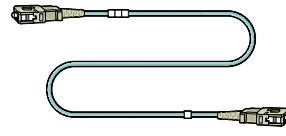
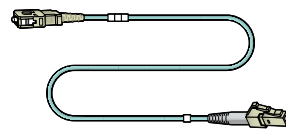
Type	Model	Length (m)
 Jacket color: AQUA Cable O.D.: 3 mm	FM33C005-S	0.5
	FM33C01-S	1
	FM33C03-S	3
	FM33C05-S	5
 Jacket color: AQUA Cable O.D.: 2 mm	FM32C005-SS	0.5
	FM32C01-SS	1
	FM32C03-SS	3
	FM32C05-SS	5
 Jacket color: AQUA Cable O.D.: 2 mm	FM32C005-SS/LS	0.5
	FM32C01-SS/LS	1
	FM32C03-SS/LS	3
	FM32C05-SS/LS	5

- Fiber type : Multi-mode 50/125 OM3
- Typically used in 10 Gigabit Ethernet
- Minimum bend radius: 10 mm

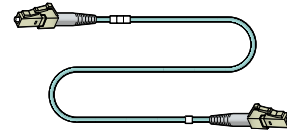
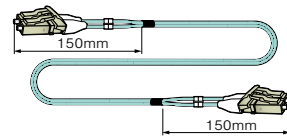
Type	Model	Length (m)
 Jacket color: AQUA Cable O.D.: 2 mm	FM32C005-LS	0.5
	FM32C01-LS	1
	FM32C03-LS	3
	FM32C05-LS	5
 Jacket color: AQUA Cable O.D.: 2 mm	2FM3Z2S005-DLS	0.5
	2FM3Z2S01-DLS	1
	2FM3Z2S03-DLS	3
	2FM3Z2S05-DLS	5

- Insertion loss : 0.3 dB max.
- Return loss : 30 dB max. (PC)
- UL type OFNR

OM3 Multi-mode Fiber Optic Fan-out Cables

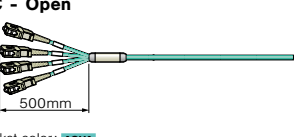
Type	Model	Length (m)
 Jacket color: AQUA	4FO-M3-015-SS	1.5
	4FO-M3-03-SS	3
	4FO-M3-05-SS	5

- 4-core Multimode 50/125 OM3 Ribbon Fiber
- Typically used in 10 Gigabit Ethernet
- Insertion loss : 0.3 dB max.
- Return loss : 30 dB max. (PC)

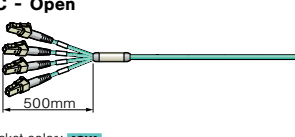
Type	Model	Length (m)
 Jacket color: AQUA	4FO-M3-015-LS	1.5
	4FO-M3-03-LS	3
	4FO-M3-05-LS	5

- Ribbon fiber cable : 2.1 × 3.5 mm outer dimensions
- Fan-out unit : 2 mm outer diameter, 500 mm length
- Fan-out tubing : 8 mm outer diameter
- UL type OFNR

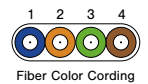

Multi-core OM3 Multi-mode Fiber Optic Cables

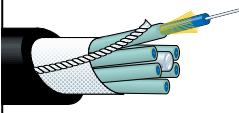
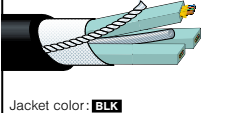
Type	Model	No. of Ch.	Sales Units (m)	Nom. O.D. (mm)	Weight kg/100m	Tension Tolerance (N)	Min. Bend Radius	Temp. Range (deg C)	Fiber-optic Unit		
									Fiber	Attenuation	Dim. (mm)
 Jacket color: BLK Unit color: AQUA	LF-M32-4C-EM	4	Call	7.4	5.6	290	6 × Nom. O.D.	-20 to +60	MM 50/125	3 dB/km @850nm 1 dB/km @1300nm	2.0 (round)
	LF-M32-6C-EM	6		9.0	7.5	300					1.5 × 2.5 (ribbon)
	LF-M32-8C-EM	8		10.1	10.8	780					
 Jacket color: BLK Unit color: AQUA	LF-M3R4-12C-EM	12 (3×4 core)		7.4	5.6	300					

Jacket material : Flame retardant PE

- OM3 fiber; typically used in 10 Gigabit Ethernet.
- Including a central strength member and a rip cord.
- Each unit has aramid strength member.